

BROUGHTONS

— LIGHTING & IRONMONGERY —

IMPORTANT PLEASE READ

Read and understand the fitting and wiring instructions before attempting to install your new switch. Consult a qualified electrician if you are unsure of the installation procedure.

FIXING INSTRUCTIONS

- 1) Minimum fixing area for the complete switch assembly, 90mm x 90mm.
- 2) Fix the switch assembly to a standard single gang BS 4662 flush wall box minimum dimensions 75mm x 75mm x 16mm deep with fixing centres of 60.3mm. The box and switch assembly shall be firmly fitted flush with the fixing surface. Centred in an area of at least 90mm x 90mm.
- 3) Allow a 5mm gap between the edges of the wooden plinth and surrounding fixtures.

DISCLAIMER

This switch is intended for domestic use only. It must be installed in accordance with the fitting instructions. It should be fitted in the approved way onto a standard flush wall box that has been fixed into a solid or stud partition wall. Wallpaper should not continue from beneath the plinth into the wall box area towards the electrical connections. The switch should not be used in areas of high humidity (bathrooms etc.) nor within reach of a water source.

The switch should be connected to a mains supply of the appropriate voltage and used within its load current rating. Maximum voltage and current ratings will be either indicated on the back of the switch or on the packaging. If unsure of how to fit the switch, consult a qualified electrician. No liability can be accepted if the switch is installed or used in any other way.

INSTALLATION INSTRUCTIONS

Before attempting to carry out any electrical work.

ISOLATE MAINS SUPPLY FROM THE INSTALLATION BY SWITCHING OFF AT THE MAIN FUSE BOX

- 1) Remove the existing switch from the wall box to reveal the electrical connections. Before touching or removing the wires, check that no mains voltage is present at the switch terminals.
- 2) Disconnect the cables from the existing switch, be sure to note how the cables are connected.
- 3) Fix the plinth (B) to the existing wall box (A) using the two screws (C), the cables should be routed through the slots in the plinth. If the existing wires are not long enough, extend them by using appropriate connectors, rated at 250 volts AC, 5 amp minimum, and lengths of insulated solid copper 1.5mm wire. The connectors must be located in the wall box.
- 4) Connect the wires to the switch (D), by referring to the connection notes made in step (2) or the wiring diagrams shown below (names in diagrams may have changed over time)
- 5) Attach the plastic moulding (E) onto the switch (D), ensuring the switch is fully inserted by compressing the 4 sprung plastic lugs on the switch, the switch will click into the base. Present the assembly to the wooden plinth ensuring that cables slide back through the slots and are not trapped between the plinth and the switch. Fix the completed assembly to the wooden plinth using the counter sunk wood screws provided (F).
- 6) Screw the finished dome (G) firmly onto the switch. Be careful not to cross thread or over tighten the dome when fitting.

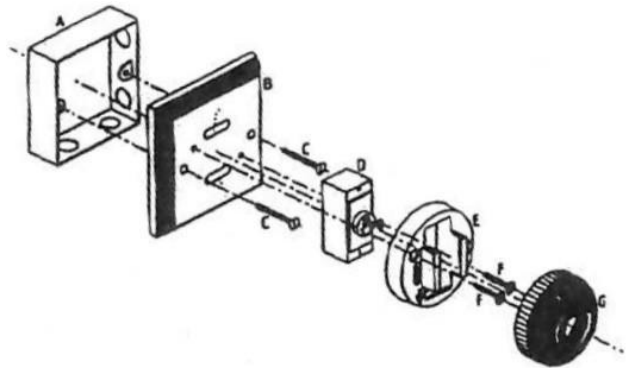
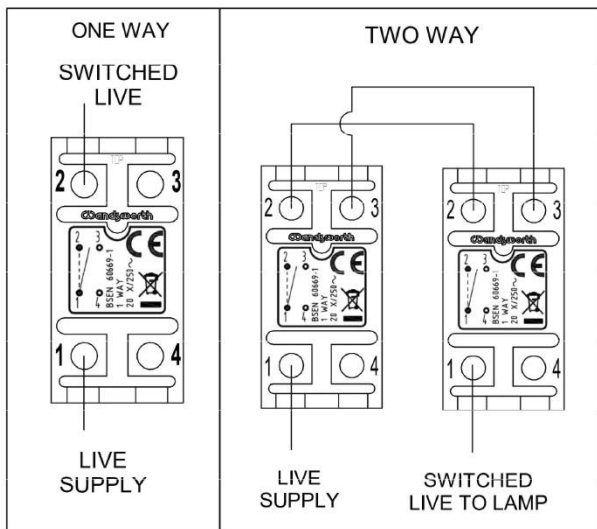

GUARANTEE

(UK & Irish Republic only)

This switch is guaranteed against faulty workmanship or materials for a period of twelve months. If found to be defective it will be repaired or replaced free of charge providing the following conditions have been met.

- a) Specified maximum rating have been not exceeded. Used only for normal internal domestic (except bathrooms) applications.
- b) The installation procedure has been carried out correctly.
- c) A dated bill of sale accompanies all returned goods.
- d) The accessory has not been taken apart, tampered with, modified, or attempted to have been repaired.

This guarantee does not affect the statutory rights of the consumer. In no circumstances can the Company accept responsibility for any loss or damage said to arise from the use of this product.

Broughtons of Leicester Ltd – T. 0116 234 1888 <http://www.broughtons.com>

E&OE